

# ESTRATTORI DI FUMO 120 - 150 PER STUFE A PELLETTA

## 120 - 150 FUME EXTRACTORS FOR PELLETTA STOVES

La chiocciola filettata e il sensore di velocità sono opzionali - Optional threaded housing and speed sensor

### ST73 - IP X5

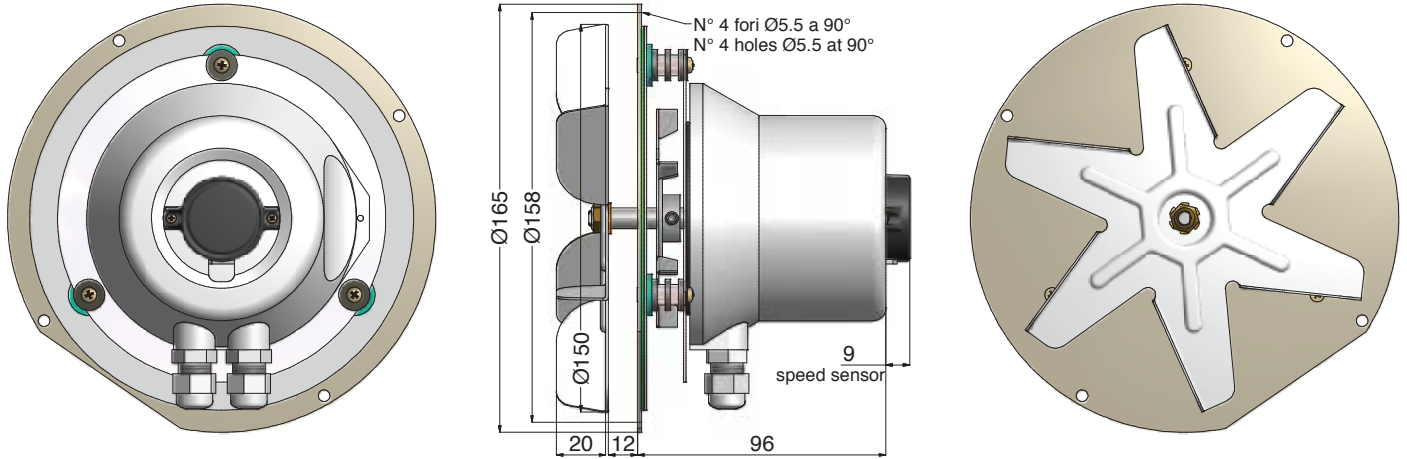

Modello	Ø Ventola	Foratura disco-flangia	Potenza assorbita [W] Corrente assorbita [A]	Velocità rpm	Pressione Max [Pa]	Portata Max [m³/h]
Model	Ø Fan	Flange drilling	Input power [W] Input current [A]	Speed rpm	Max Pressure [Pa]	Max flow rate [m³/h]
<b>1</b> •ST73 - V.230/50	<b>120 x 16</b>	Ø 158	32 W / 0,15 A	2810	229	130
<b>2</b> •ST73 - V.230/50	<b>150 x 20</b>	Ø 158	32 W / 0,14 A	2870	330	143
<b>3</b> •ST73 - V.230/50	<b>150 x 25</b>	Ø 158	32 W / 0,14 A	2860	341	148

**ST73** motore asincrono monofase. Grado di Protezione IP X5. Temperatura ambiente di esercizio -25/+70 °C

**ST73** asynchronous single-phase motor. IP X5 Protection. Operating ambient temperature -25/+70 °C

### ST 73 120.16

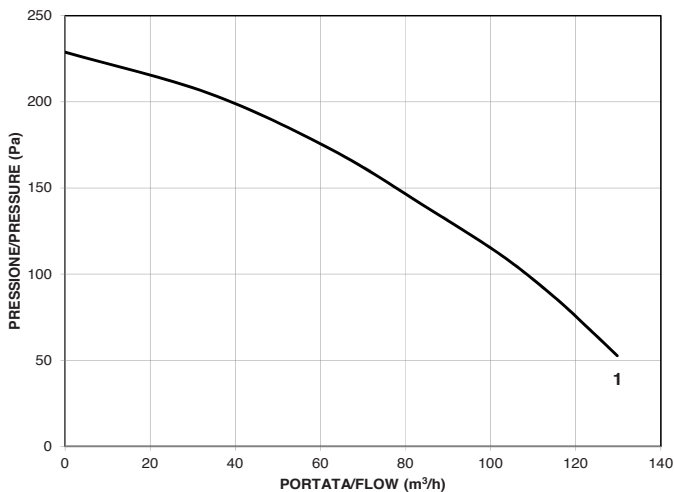

### ST 73 150.20-25

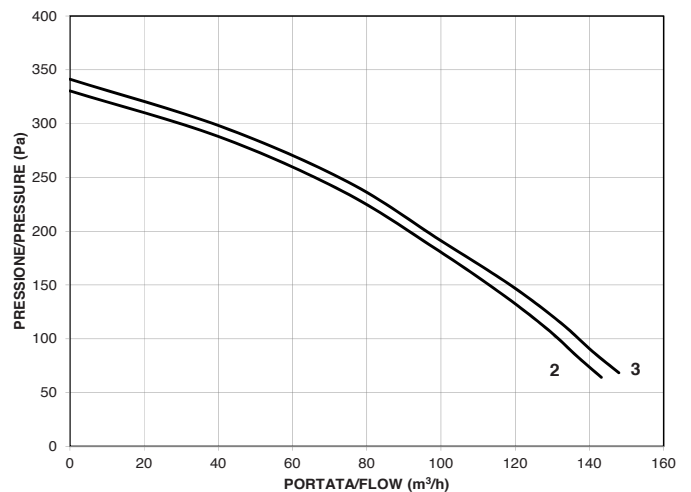

"Le illustrazioni hanno solo scopo dimostrativo e non costituiscono obbligo di fedele riproduzione. Caratteristiche, dimensioni, pesi e misure non sono vincolanti. AACO si riserva il diritto di apportare le modifiche che ritiene indispensabili al fine di migliorare i propri prodotti."



"The illustrations are for demonstration purposes only and do not constitute obligation to faithful reproduction. Characteristics, dimensions, weights and measures are not binding. AACO reserves the right to make any changes deemed necessary to improve its products"

# ESTRATTORI DI FUMO 120 - 150 PER STUFE A PELLETT 120 - 150 FUME EXTRACTORS FOR PELLETT STOVES

La chiocciola in lamiera verniciata e il sensore di velocità sono opzionali - Optional painted housing and speed sensor

## ST20 - 25 - 53 - 73 V. 120 Hz. 60 VERSION

Modello	Ø Ventola	Foratura disco-flangia	Potenza assorbita [W] Corrente assorbita [A]	Velocità rpm	Pressione Max [Pa]	Portata Max [m³/h]
Model	Ø Fan	Flange drilling	Input power [W] Input current [A]	Speed rpm	Max Pressure [Pa]	Max flow rate [m³/h]
<b>ST20 - ORARIO - CLOCKWISE (R)</b>						
<b>1●ST20 - V.120/60</b>	<b>120 x 16</b>	Ø 158	48 W / 0,50 A	3288	279	135
<b>2●ST20 - V.120/60</b>	<b>150 x 20</b>	Ø 158	53 W / 0,50 A	3216	349	141
<b>ST25 - ORARIO - CLOCKWISE (R)</b>						
<b>3●ST25 - V.120/60</b>	<b>120 x 16</b>	Ø 158	60 W / 0,57A	3360	293	138
<b>4●ST25 - V.120/60</b>	<b>150 x 20</b>	Ø 158	62 W / 0,60 A	3312	390	144
<b>5●ST25 - V.120/60</b>	<b>150 x 25</b>	Ø 158	62 W / 0,60 A	3300	411	150
<b>ST53-73 - ORARIO - CLOCKWISE (R)</b>						
<b>6●ST53-73 - V.120/60</b>	<b>120 x 16</b>	Ø 158	38 W / 0,23 A	3372	298	144
<b>7●ST53-73 - V.120/60</b>	<b>150 x 20</b>	Ø 158	38 W / 0,21 A	3444	430	159
<b>8●ST53-73 - V.120/60</b>	<b>150 x 25</b>	Ø 158	38 W / 0,21 A	3430	444	164

**ST20 - 25** motori a poli schermati, cuscinetti a sfere. Grado di Protezione IP 20. Temp. ambiente di esercizio -25/+75°C  
**ST20 - 25** shaded-poles motors, shielded ball bearings. IP 20 Protection. Operating ambient temperature -25/+75°C

**ST53 e ST73** motore asincrono monofase. Temperatura ambiente di esercizio -25/+70 °C

**ST53 e ST73** asynchronous single-phase motor. Operating ambient temperature -25/+70 °C

### ST 20

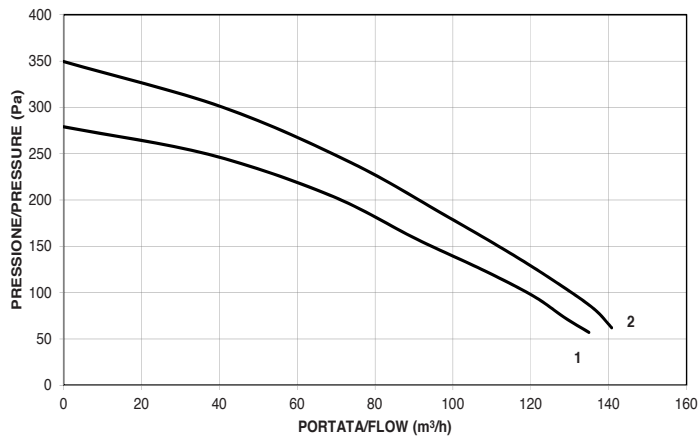

### ST 25

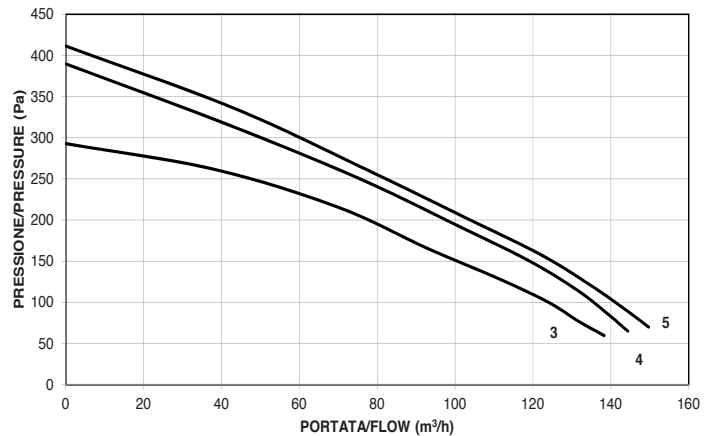

### ST 53

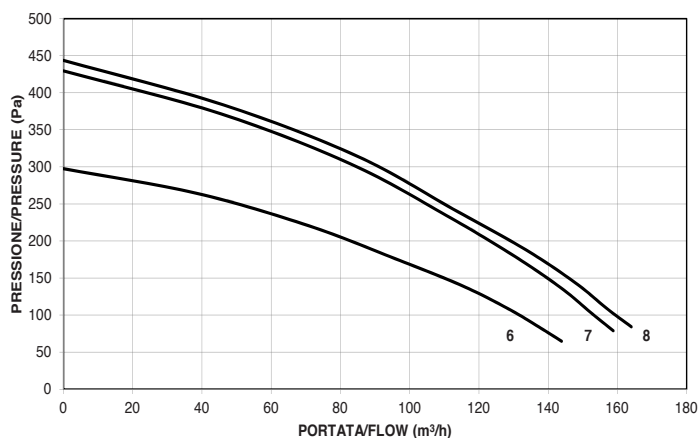

### ST 73

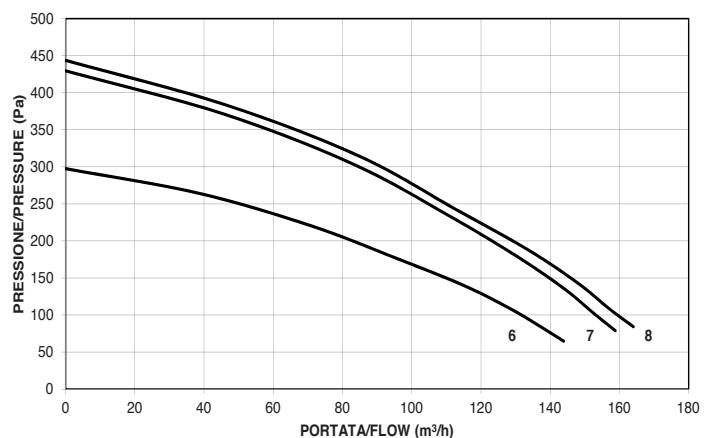

"Le illustrazioni hanno solo scopo dimostrativo e non costituiscono obbligo di fedele riproduzione. Caratteristiche, dimensioni, pesi e misure non sono vincolanti. AACO si riserva il diritto di apportare le modifiche che ritiene indispensabili al fine di migliorare i propri prodotti."



"The illustrations are for demonstration purposes only and do not constitute obligation to faithful reproduction. Characteristics, dimensions, weights and measures are not binding. AACO reserves the right to make any changes deemed necessary to improve its products"